

# KINLEY

## Haleyon

2 BEDROOMS  
1 CAR PARKING SPACE

GROUND FLOOR	95 m <sup>2</sup>
NSA	95 m <sup>2</sup>
GARAGE	27 m <sup>2</sup>
PORCH	4 m <sup>2</sup>
ALFRESCO	12 m <sup>2</sup>
GFA	138 m <sup>2</sup>

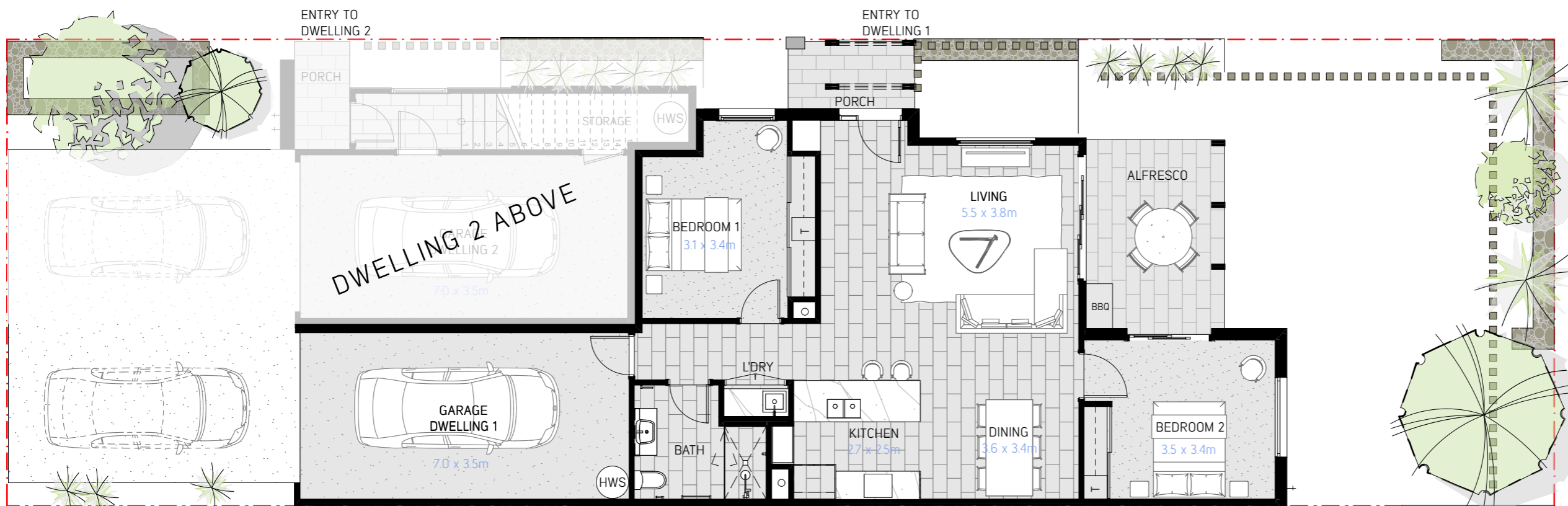

TEMPLAR LANE

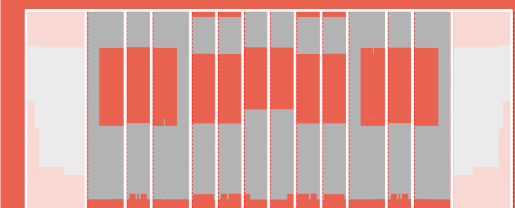

Halcyon



Halcyon

AVANT  
TOWNHOMES

INTRAPAC  
PROPERTY



# Plans

## Haleyon

- LT-01 LED DOWNLIGHT  
E - FOR EXTERNAL SOFFITS
- ⊙ LT-02 PENDANT / STRIP LIGHT  
OVER KITCHEN BENCH
- LT-03 KITCHEN O/HEAD LED.
- LT-04 STAIR LIGHT
- ⊕ LT-05 WALL LIGHT - EXTERNAL
- LT-06 LED DOWNLIGHT - SURFACE MOUNTED  
FOR HALCYON HOUSE TYPE ONLY
- ⊗ LT-07 LIGHT IN CUPBOARD OR ROOF
- ⊕ LT-08 ROOF DECK LIGHT
- ⊕ TELEVISION POINT  
OUTLET TO ALLOW FOR TV ANTENNA AND CABLE TV
- ⊕ CAT 6 CABLE POINT  
OUTLET TO ALLOW FOR TELEPHONE AND DATA
- SD ○ SMOKE DETECTOR
- ▲ SINGLE GPO      ▲ DOUBLE GPO
- × SWITCH      ×D SWITCH WITH DIMMER
- 2W 2 WAY SWITCH
- ⊗ CEILING EXHAUST FAN
- ⊗ CEILING EXHAUST FAN  
+ DOWNLIGHT
- ⊗ RANGEHOOD EXHAUST
- ▭ DB DISTRIBUTION BOARD
- OPTI INTERNET SUPPLY POINT
- DATA MODEM / ROUTER POINT

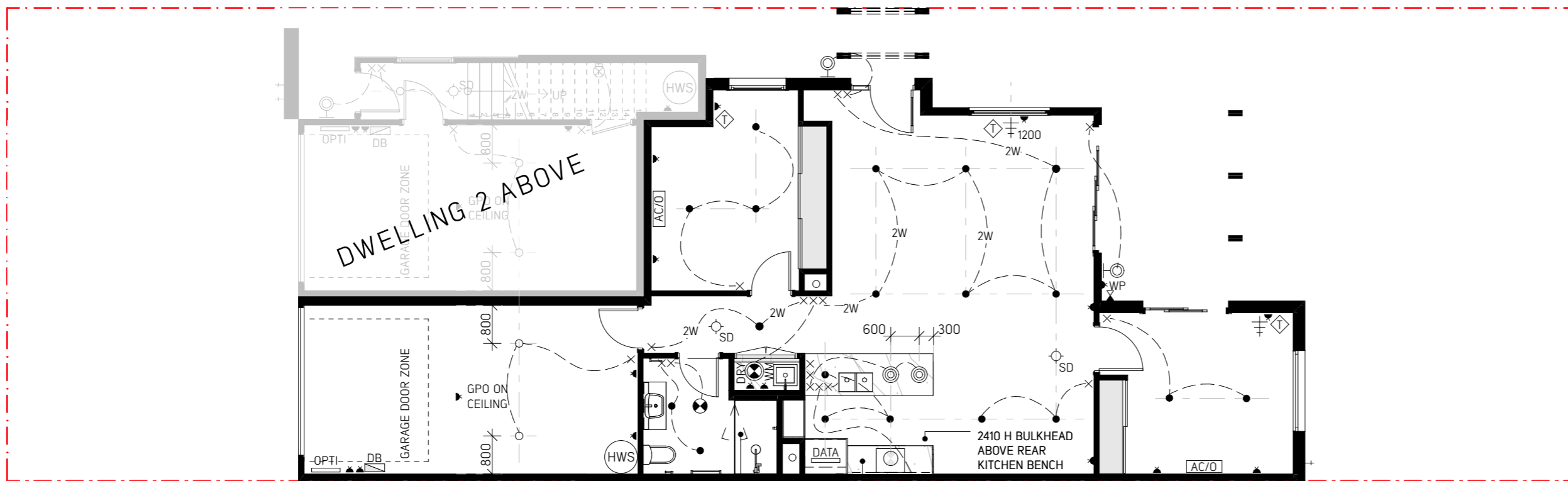

REFER TO INTERIORS DRAWINGS  
FOR GPO LOCATIONS  
IN THE BATHROOM

REFER TO INTERIORS  
DRAWING FOR GPO  
LOCATIONS IN THE KITCHEN

**NOTE:**  
FIRE RATED CEILING NOT LESS THAN 30/30/30  
THROUGHOUT GROUND FLOOR UNIT -  
ALL DOWNLIGHTS TO BE SURFACE MOUNTED

### TEMPLAR LANE

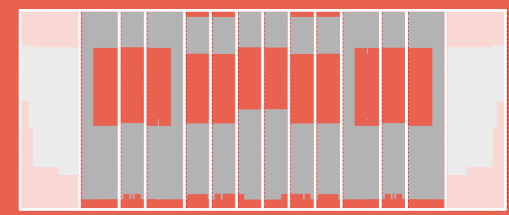

AVANT  
TOWNHOMES

INTRAPAC  
PROPERTY



# Electrical

# KINLEY

# Haleyon

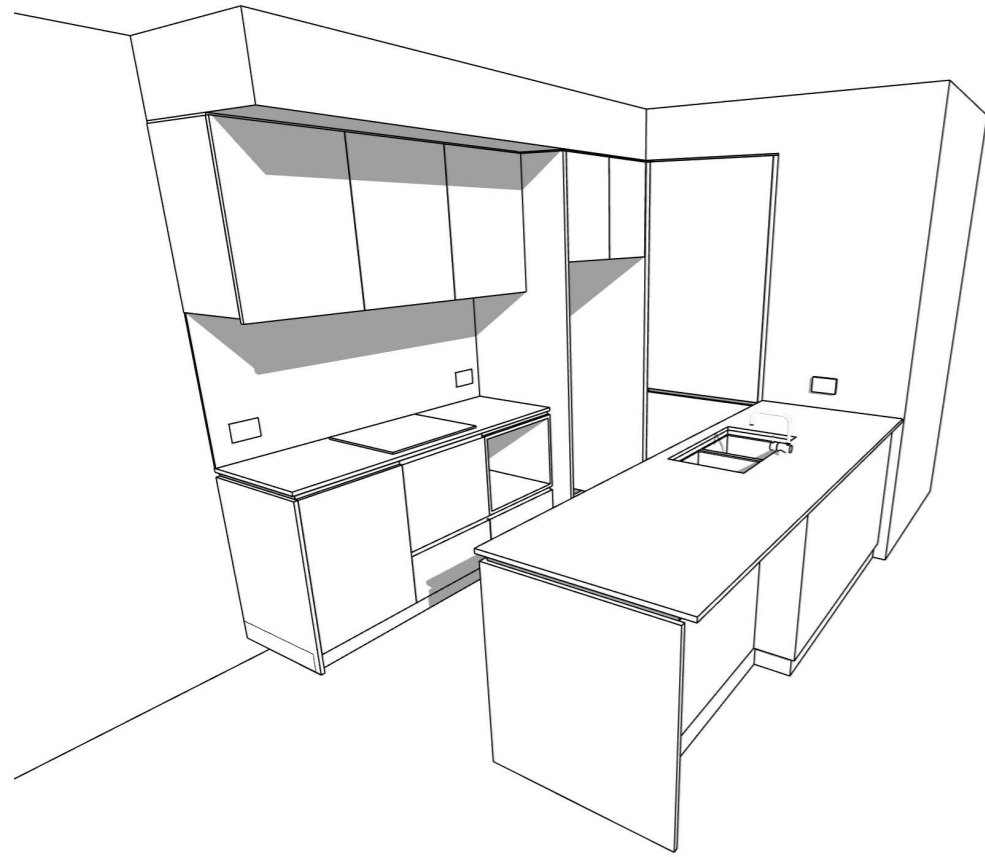

HALCYON 3D VIEW 1

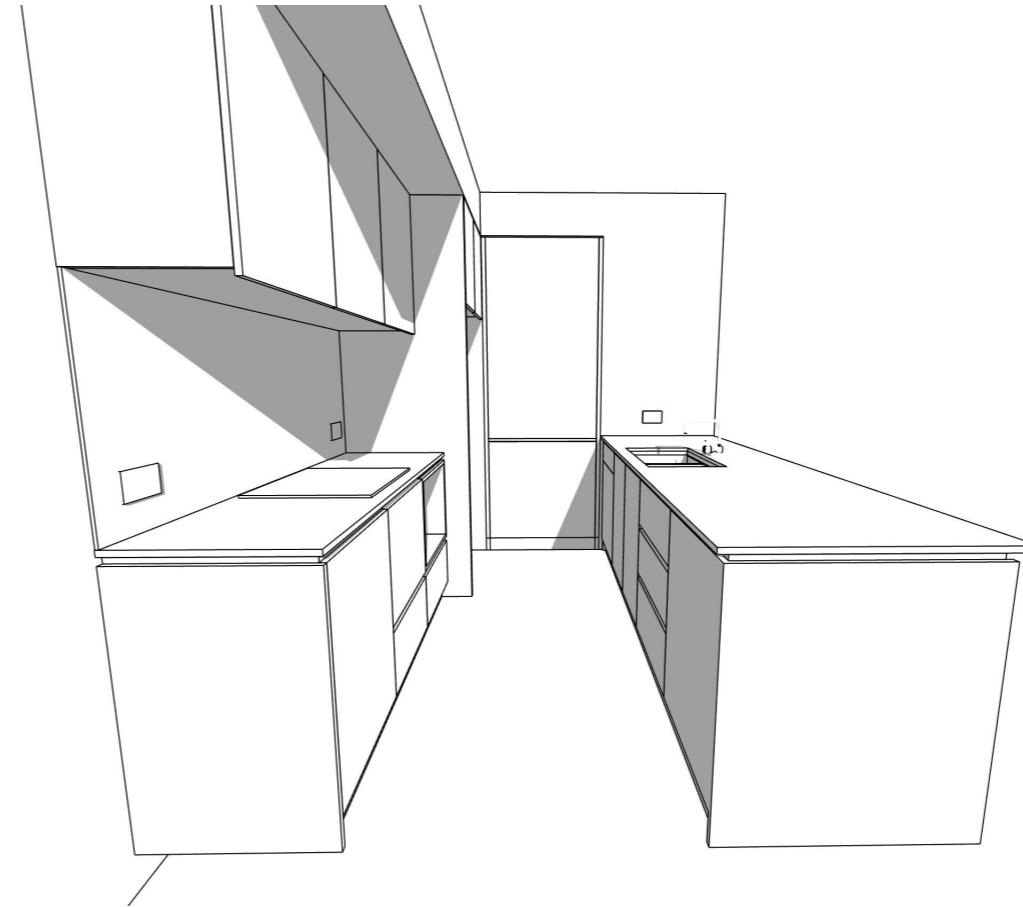

HALCYON 3D VIEW 2

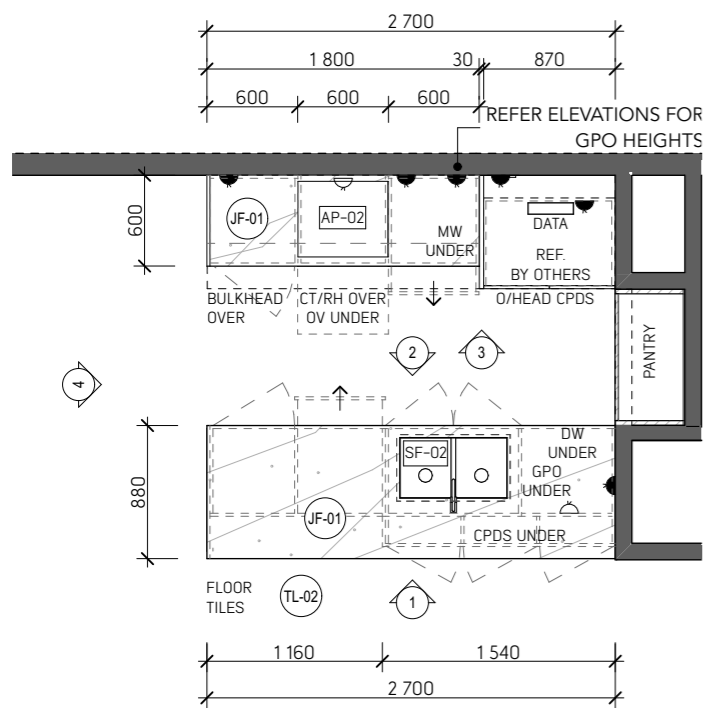

KITCHEN - HALCYON

1:50

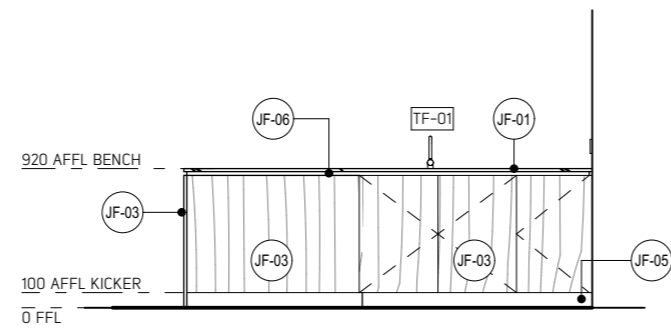

ELEVATION 01

1:50

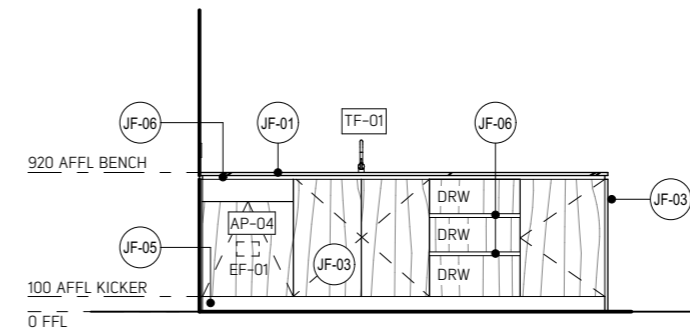

ELEVATION 02

1:50

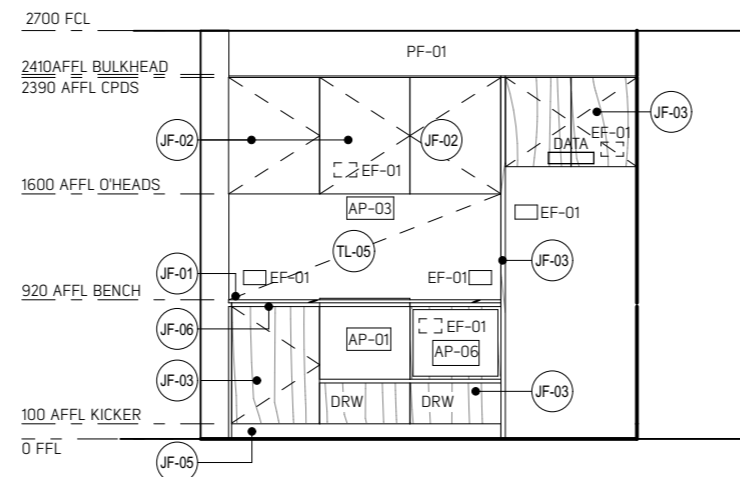

ELEVATION 03

1:50

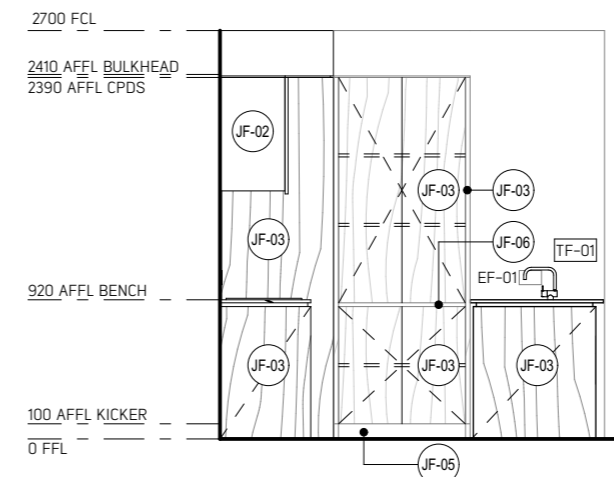

ELEVATION 04

1:50

TEMPLAR LANE

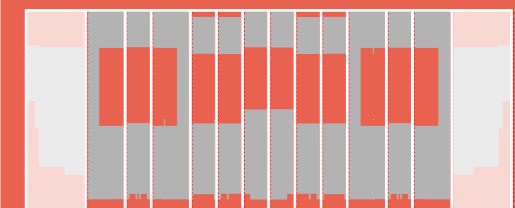

AVANT  
TOWNHOMES

INTRAPAC  
PROPERTY



# Kitchen

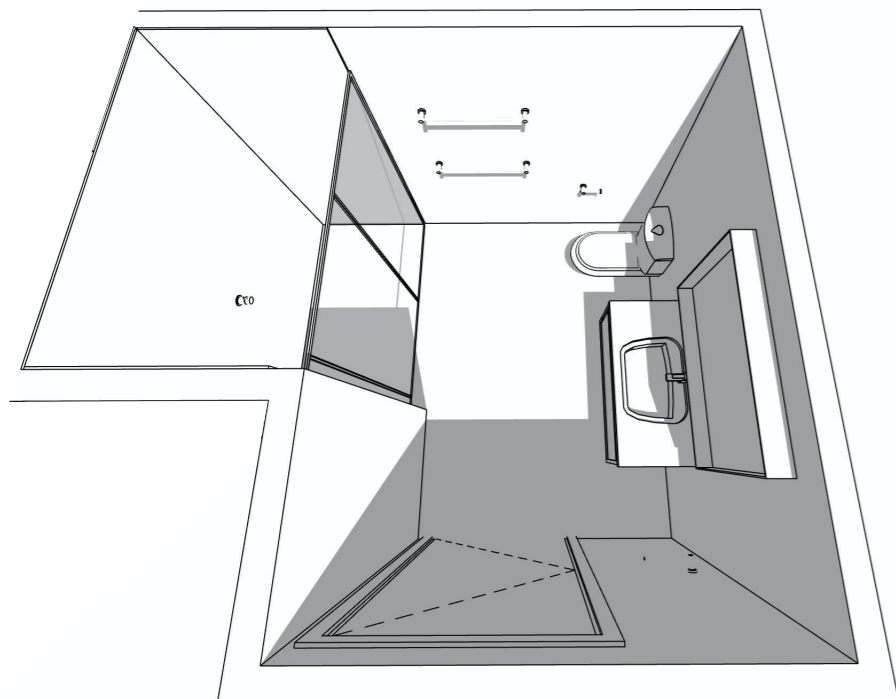

BATHROOM TYPE C 3D VIEW

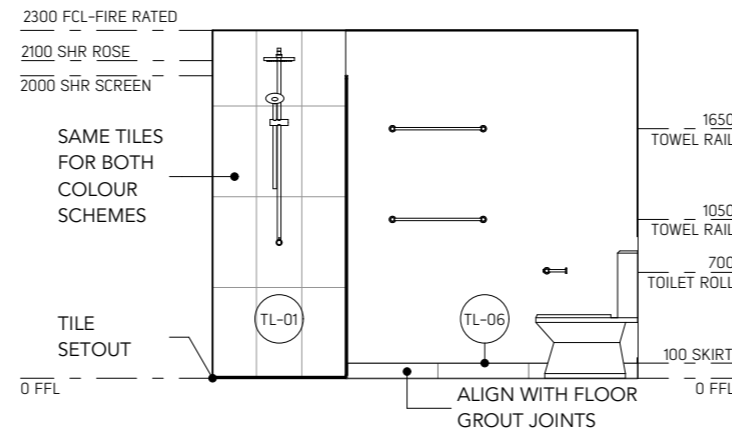

ELEVATION 01 1:50

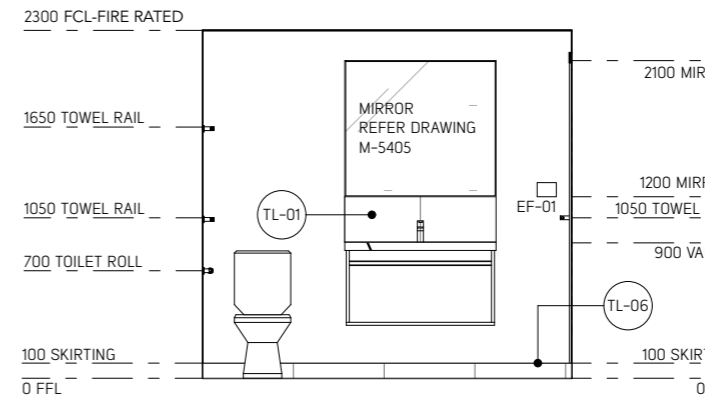

ELEVATION 02 1:50

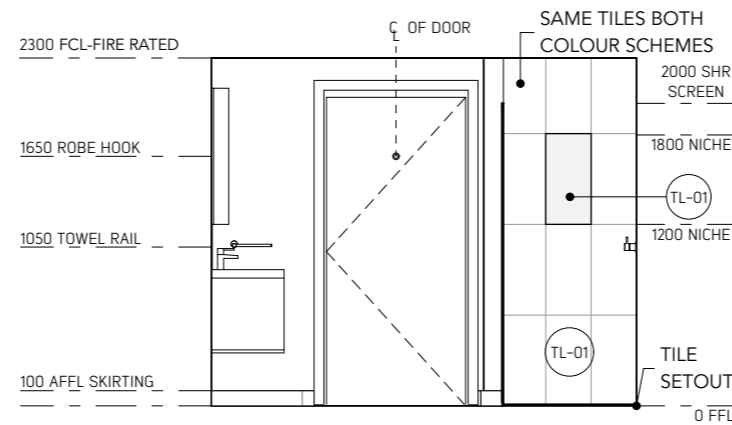

ELEVATION 03 1:50

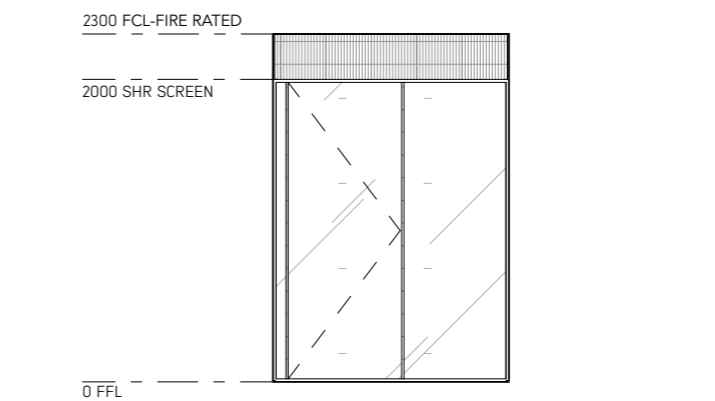

ELEVATION 04 1:50

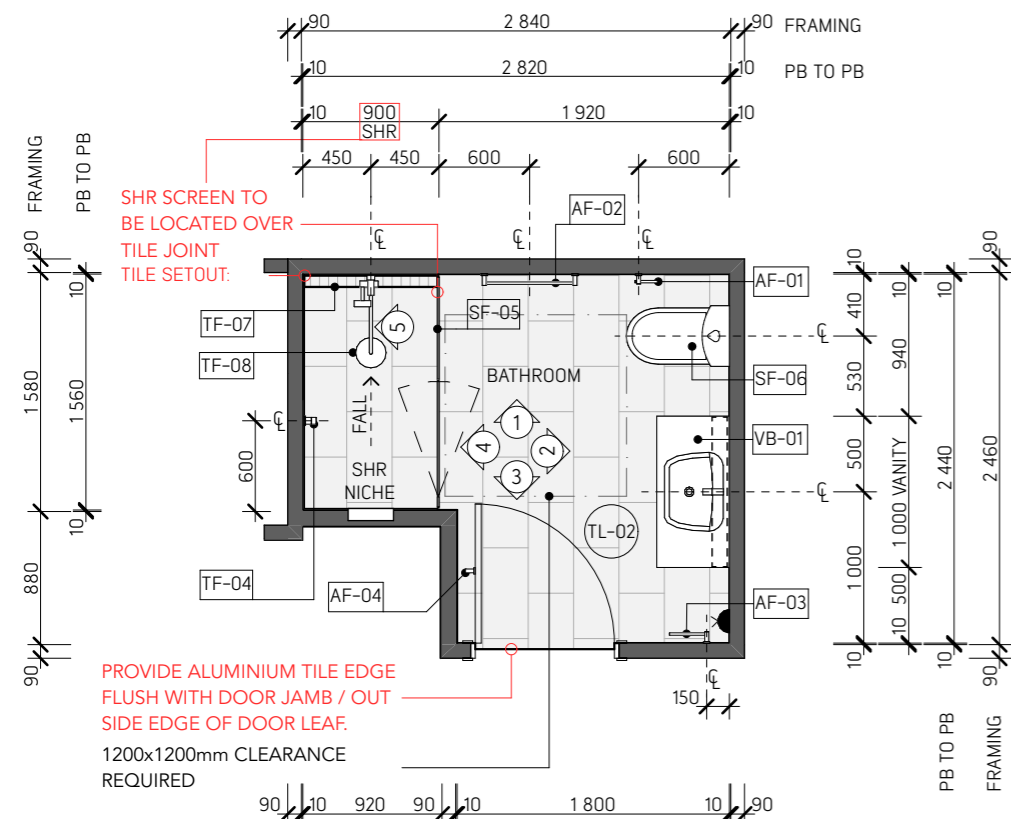

BATHROOM - TYPE C 1:50

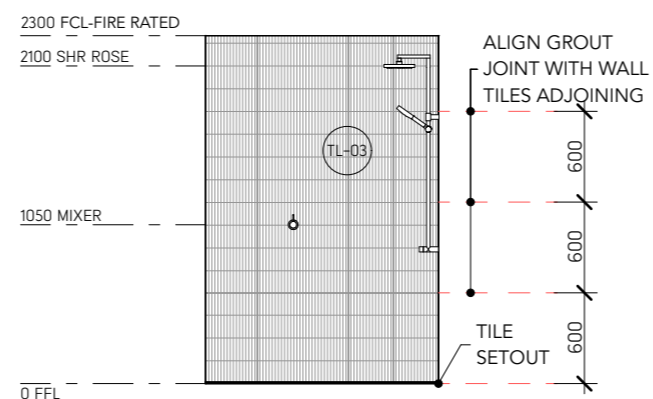

ELEVATION 05 - DARK 1:50

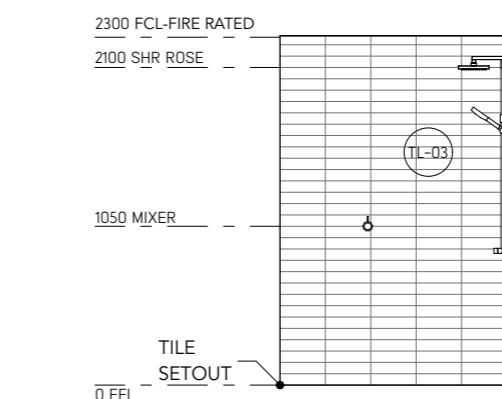

ELEVATION 05 - LIGHT 1:50

TEMPLAR LANE

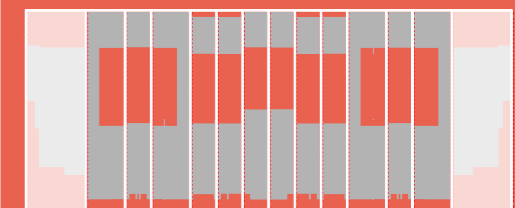

AVANT TOWNHOMES

INTRAPAC PROPERTY



# Bathroom